

VCA(P8)TG4/(P239)TG18
VCA 4



DEPARTMENT OF TRANSPORT
ROOM 805
TOLLGATE HOUSE, HOULTON STREET,
BRISTOL BS2 9DJ

Direct line 0272-218515
Switchboard 0272-218811
Telex 449321



COMMUNICATION CONCERNING THE APPROVAL (OR WITHDRAWAL OF APPROVAL)
OF A TYPE OF DEVICE FOR ILLUMINATING REAR REGISTRATION PLATES
PURSUANT TO REGULATION NO 4

9088^{R4} 00 ONLY

Approval No: 4248

1. Device: Rear registration plate lamp incorporated in the type 9088 series grouped rear lamp unit to illuminate both wide and tall rear registration plate.
2. trade name or mark: Britax and Vignal
3. Manufacturer's name: Britax (PMG) Ltd
4. Name of his representative (if applicable): N/A
5. Address: Bessingby Industrial Estate, Bridlington, North Humberside YO16 4SJ, England.
6. Type, number and power of lamps: P21/5W. One 12v21/5W.5W operating
7. Submitted for approval on: March 23 1988
8. Test Laboratory: British Standards Institution
9. Date of laboratory report: May 13 1988
10. Number of laboratory report: 130562/2-2
11. Date of approval: As at item 14
12. Date of withdrawal of approval: N/A
13. Place: BRISTOL
14. Date: 5 OCTOBER 1988
15. Signature: *P F Nicholl* P F NICHOLL
16. The attached drawing shows geometrically the position in which the illuminating device is to be fitted in relation to the space to be occupied by the registration plate and the outlines of the adequately illuminated area. The size of this drawing should be of maximum format A.4 (210 x 297 mm).

* Strike out whichever does not apply



VEHICLE CERTIFICATION AGENCY

1 The Eastgate Office Centre
Eastgate Road
Bristol BS5 6XX
United Kingdom

☎ Switchboard 0117 951 5151
☎ Direct Line 0117 952 41
Fax: 0117 952 4103

THE UNITED KINGDOM VEHICLE APPROVAL AUTHORITY



Rev 9/92

COMMUNICATION CONCERNING THE APPROVAL GRANTED OF A TYPE OF
DIRECTION INDICATOR PURSUANT TO REGULATION NO 6.01

Approval No : 01781

Extension No : 2

1. Device of category 2a, which may not be used in a combination of two lamps.
2. Category and number of filament lamps : One P21W 21 Watt
3. For category 2b indicators, indicate the system used to obtain the night-time intensity (give the main characteristics) : Not applicable
4. Trade name or mark of the device : Britax, Rinder, KramerAllrad
5. Manufacturer's name and address :
Britax (PMG) Limited
Bessingby Industrial Estate
Bridlington
North Humberside
Y016 4SJ
United Kingdom
6. If applicable, name and address of manufacturer's representative : Not applicable
7. Submitted for approval on : As before and 14 June 1996
8. Technical service responsible for conducting approval tests : BSI Testing
9. Date of Test Report issued by that service : As before and 12 July 1996

10. Number of Test Report issued by that service : As before and PM000984
11. Approval GRANTED
12. For replacement on vehicles in use only : NO
13. This type of direction indicator is grouped/reciprocally* incorporated with lamps of the categories/types* : Not applicable
14. Reason(s) for extension (if applicable) : Extension to the latest requirements and delete ' Vignals' trademark and add KramerAllrad
15. Place : BRISTOL
16. Date 5 AUGUST 1996
17. Signature :  P F NICHOLL
18. The attached Drawing No : BS 1186 shows the characteristics; in what position geometrically, the device is to be mounted on the vehicle; and the axis of reference and centre of reference of the device.



VEHICLE CERTIFICATION AGENCY

1 The Eastgate Office Centre
Eastgate Road
Bristol BS5 6XX

☎ Switchboard 0117 951 5151
☎ Direct Line 0117 952 41
Fax: 0117 952 4103

THE UNITED KINGDOM VEHICLE APPROVAL AUTHORITY



Rev 7/93

COMMUNICATION CONCERNING THE APPROVAL GRANTED OF A TYPE OF
DEVICE PURSUANT TO REGULATION NO 7.02

Approval No : 02 975

Extension 2

1. Trade name or mark of the device : Britax, Rinder, KramerAllrad
2. Manufacturer's name for the type of device : 9088 and 9089
3. Manufacturer's name and address : Britax (PMG) Limited
Bessingby Industrial Estate
Bridlington
North Humberside
Y016 4SJ
United Kingdom
4. If applicable, name and address of manufacturer's representative : Not applicable
5. Submitted for approval on : As before and 14 June 1996
6. Technical service responsible for conducting approval tests : BSI Testing
7. Date of Report issued by that service : As before and 12 July 1996
8. Number of Report issued by that service : As before and PM000952/2-2

9. Concise description :
- By category of lamp : R-S1
- Colour of light emitted : Red
- Number and category of filament lamp(s) : 1 x P21/5W
10. Position of the approval mark : Moulded on lens
11. Reason(s) for extension (if applicable) : For approval to latest requirements and delete ' Vignals ' trademark and add KramerAllrad.
12. Approval GRANTED
13. Place : BRISTOL
14. Date 5 AUGUST 1996
15. Signature :  P F NICHOLL
16. The list of documents deposited with the Administrative Service which has granted approval is annexed to this communication and may be obtained on request.

DEFINED ILLUMINATING SURFACE

VCA Job No : P95-96/0470

Manufacturer : Britax (PMG) Limited

Unit Identification : 9088 and 9089

Definition of the limits of illuminating surface in accordance with ECE Regulations

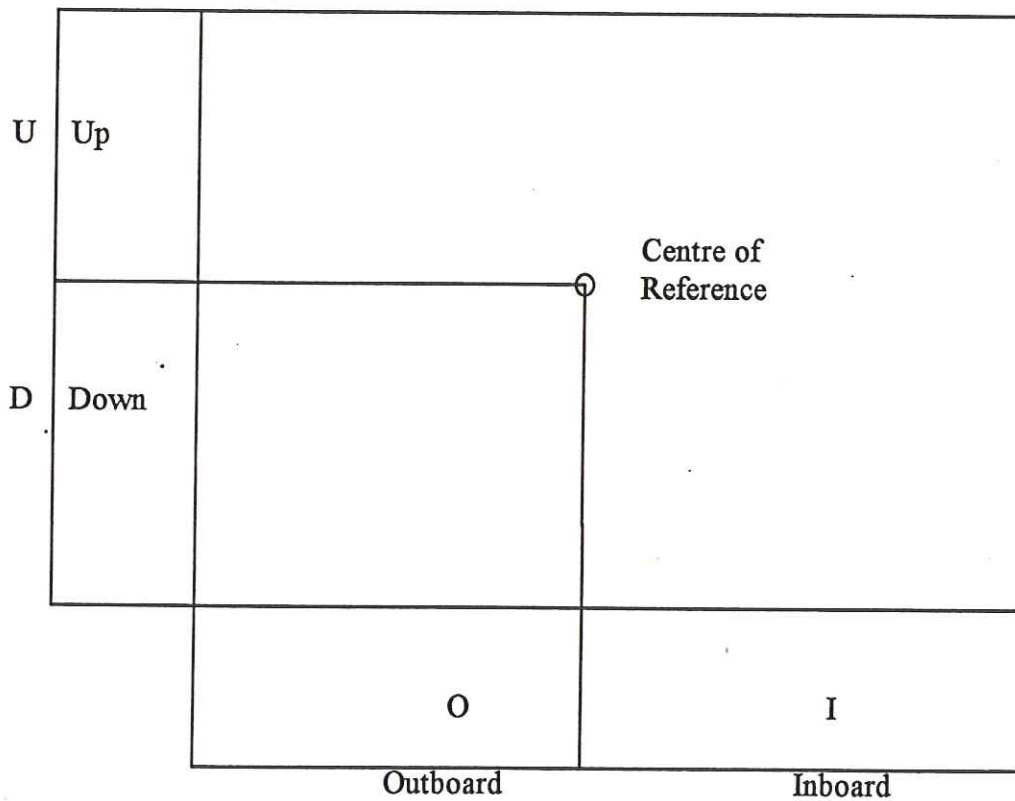

Sample	Upper limit (U) mm	Lower limit (D) mm	Outer limit (O) mm	Inner limit (I) mm
9088 (DI)	15	15	36	32
9089 (DI)	13	17	32	32

REAR POSITION (SIDE) / INDICATOR AND NUMBER PLATE LAMP

9088 SERIES

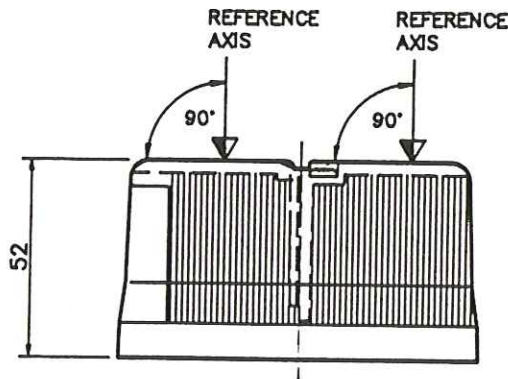
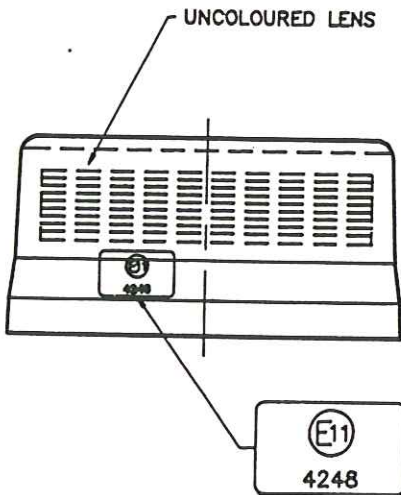
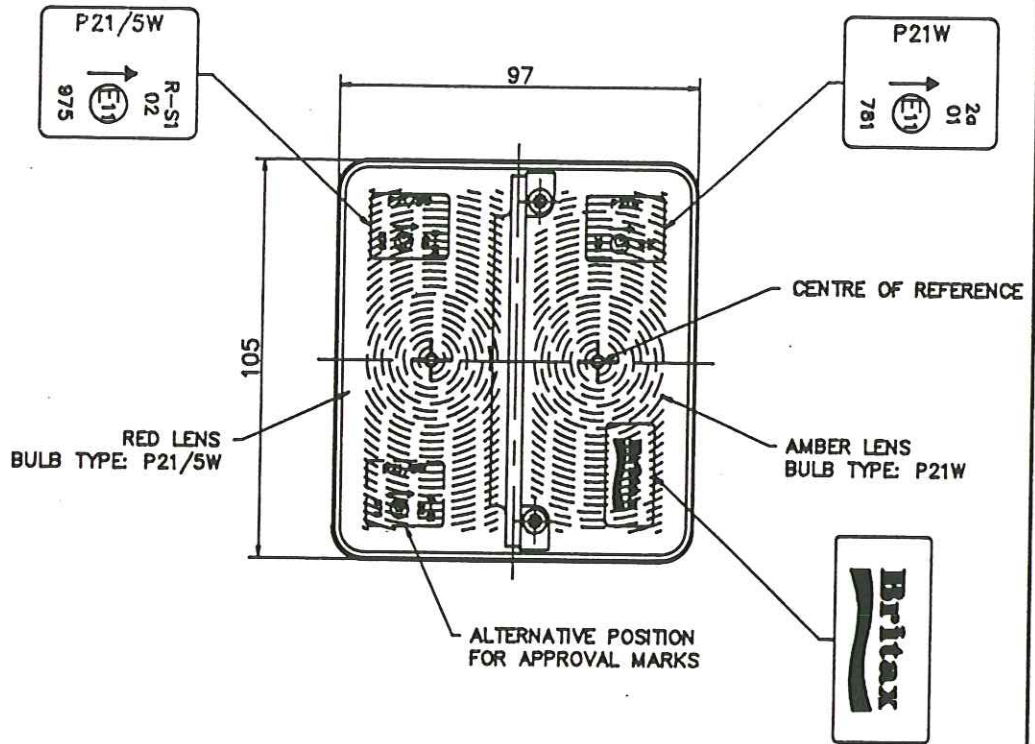

RIGHT HAND, AS DRAWN
LEFT HAND, SYMMETRICALLY OPPOSITE
REFERENCE AXIS, PARALLEL WITH ROAD SURFACE AND PARALLEL WITH THE VEHICLE MEDIAN LONGTUDINAL VERTICAL PLANE
THERMOPLASTIC BASE, BLACK
THERMOPLASTIC LENS, AMBER/ RED/ UNCOLOURED
LAMP MUST BE MOUNTED VERTICALLY WITH DIRECTION INDICATOR OUTERMOST OR HORIZONTALLY WITH DIRECTION INDICATOR UPPERMOST.



BRITAX (P.M.G.) LTD.
BESSINGBY INDUSTRIAL ESTATE,
BRIDLINGTON
EAST YORKSHIRE, YO16 4SJ

BS 1180
Sht 1 of 6

R 0420	PRODUCTION REL	A	08/05/96	D.R.	BY
MOD No	REFERENCE	ISS	DATE		

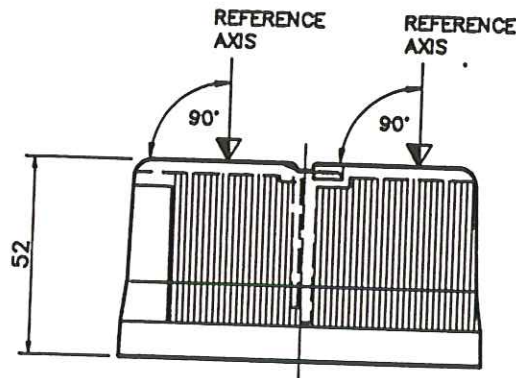
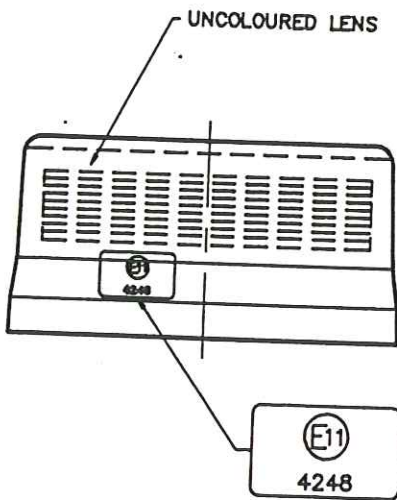
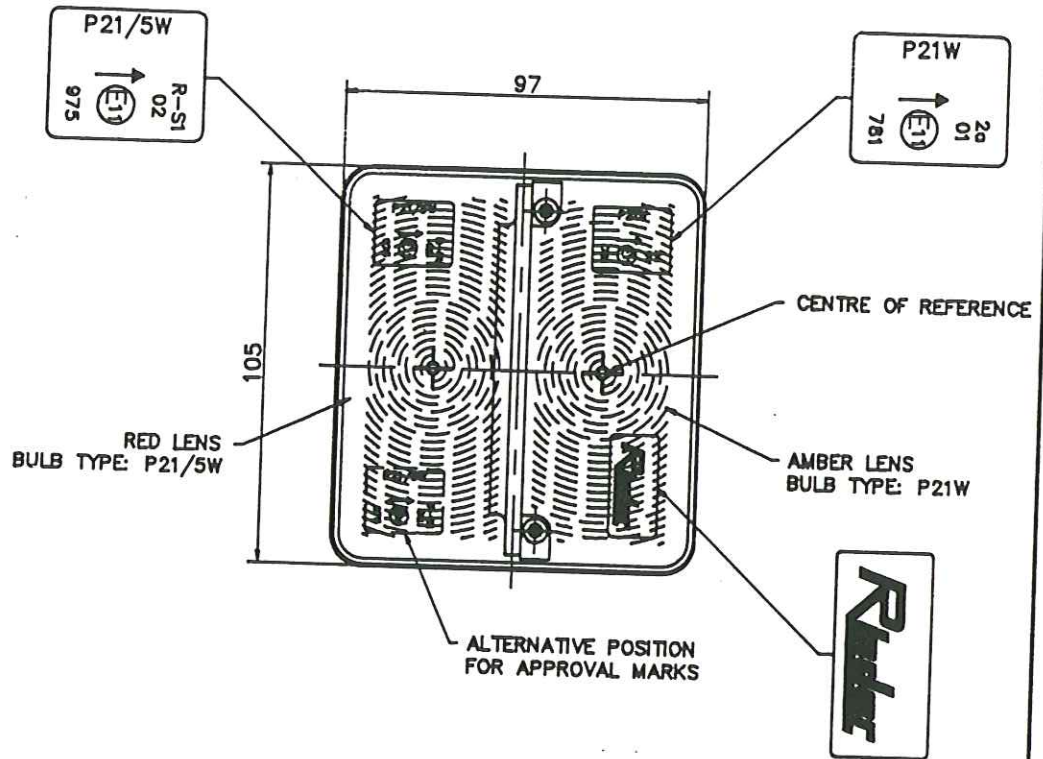

RIGHT HAND, AS DRAWN
 LEFT HAND, SYMMETRICALLY OPPOSITE
 REFERENCE AXIS, PARALLEL WITH ROAD SURFACE AND PARALLEL
 WITH THE VEHICLE MEDIAN LONGTITUDINAL VERTICAL PLANE
 THERMOPLASTIC BASE, BLACK
 THERMOPLASTIC LENS, AMBER/ RED/ UNCOLOURED
 LAMP MUST BE MOUNTED VERTICALLY WITH DIRECTION INDICATOR
 OUTERMOST OR HORIZONTALLY WITH DIRECTION INDICATOR UPPERMOST.



BRITAX (P.M.G.) LTD.
 BESSINGBY INDUSTRIAL ESTATE,
 BRIDLINGTON
 EAST YORKSHIRE, YO16 4SJ

BS 1180
 Sht 2 of 6

R 0420	PRODUCTION REL.	A	08/05/96	D.R.	BY
MOD No	REFERENCE	ISS	DATE		

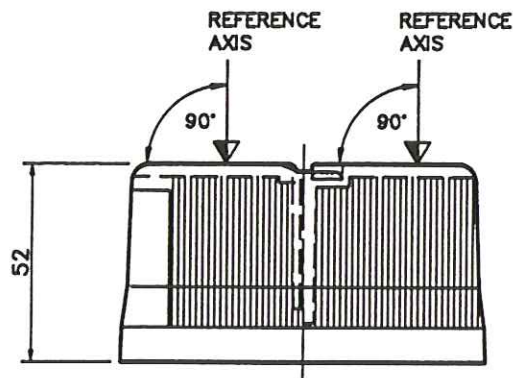
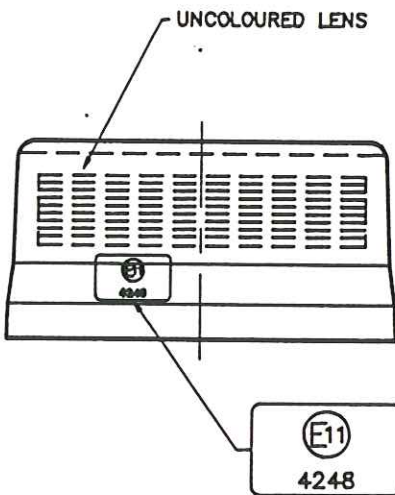
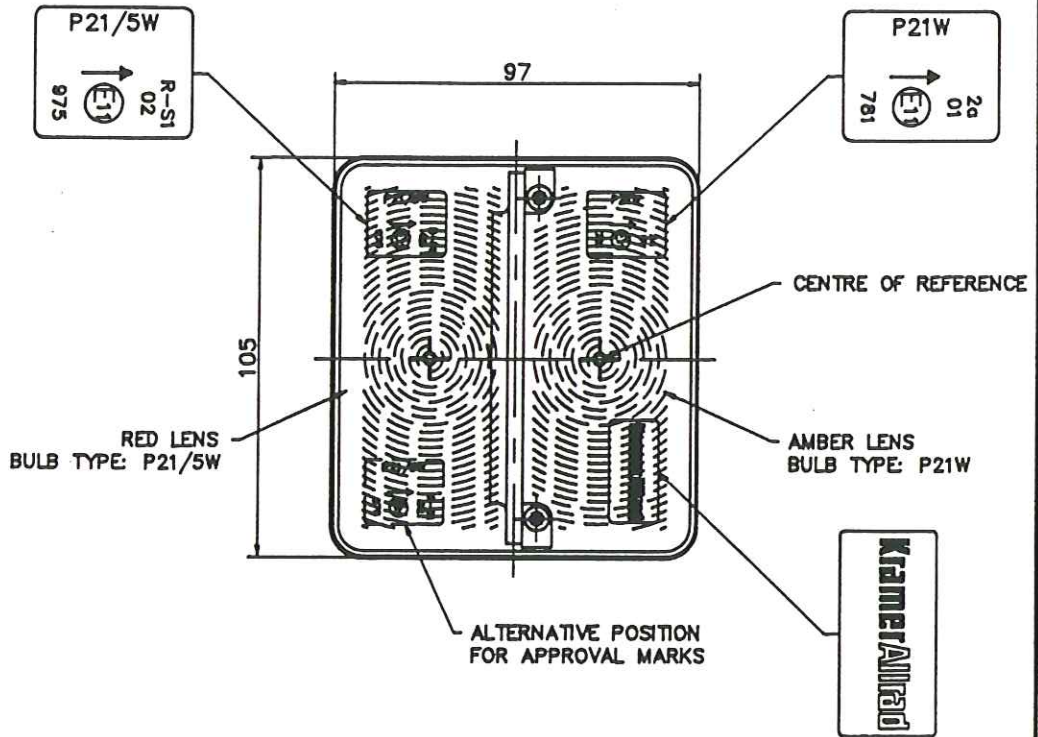

RIGHT HAND, AS DRAWN
LEFT HAND, SYMMETRICALLY OPPOSITE
REFERENCE AXIS, PARALLEL WITH ROAD SURFACE AND PARALLEL WITH THE VEHICLE MEDIAN LONGTITUDINAL VERTICAL PLANE
THERMOPLASTIC BASE, BLACK
THERMOPLASTIC LENS, AMBER/ RED/ UNCOLOURED
LAMP MUST BE MOUNTED VERTICALLY WITH DIRECTION INDICATOR OUTERMOST OR HORIZONTALLY WITH DIRECTION INDICATOR UPPERMOST.

R 0420
MOD No
PRODUCTION REL. A
ISS
DATE
BY



BRITAX (P.M.G.) LTD.
BESSINGBY INDUSTRIAL ESTATE,
BRIDLINGTON
EAST YORKSHIRE, YO16 4SJ

BS 1180
Sht 3 of 6

INSTALLATION OF 9088 COMBINATION LAMP TO COMPLY WITH
LEGAL REQUIREMENTS FOR NUMBER PLATE ILLUMINATION.

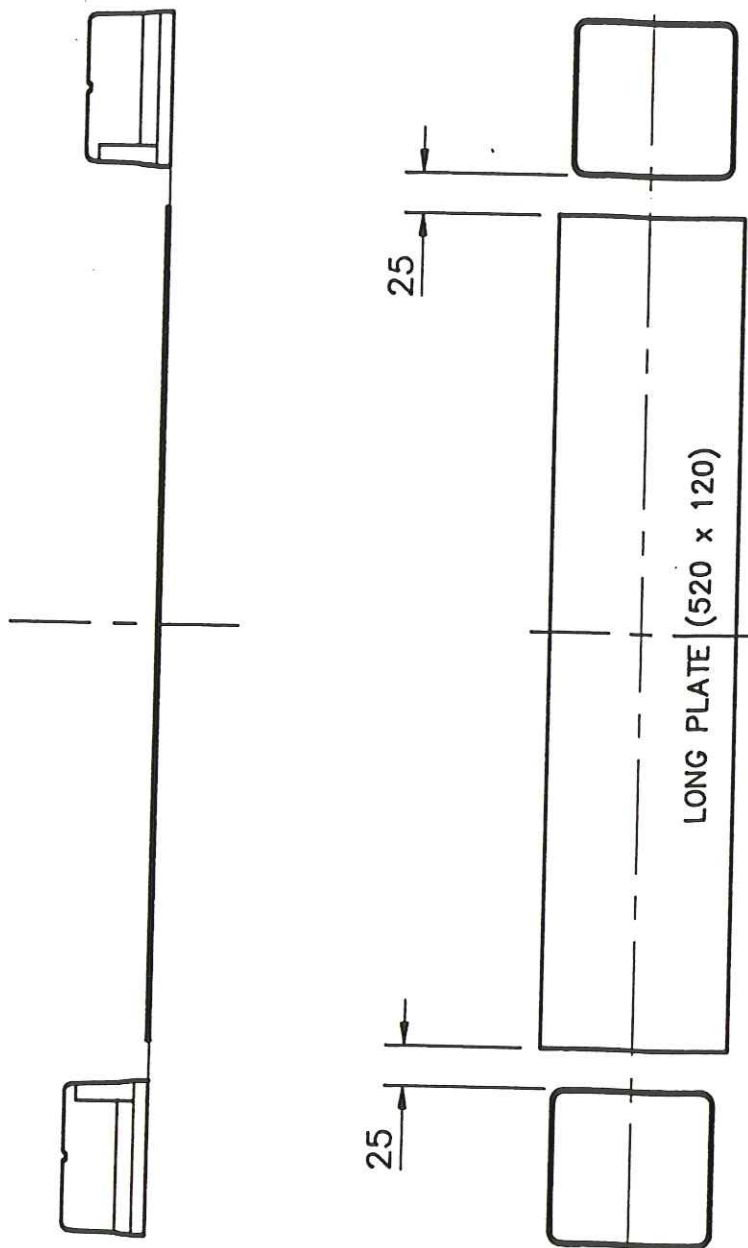

APPROVED MOUNTING POSITIONS



NOTE: MOUNTING SURFACE OF LAMP TO BE PARALLEL WITH
VERTICAL SURFACE OF THE REGISTRATION PLATE.
DIMENSIONS ARE MEASURED FORM THE BOTTOM EDGE OF
THE LAMP TO THE EDGE OF THE REGISTRATION PLATE.

R 0420	PRODUCTION	A	08/05/96	D.R.
MOD No	REFERENCE	ISS	DATE	BY



BRITAX (P.M.G.) LTD.
BESSINGBY INDUSTRIAL ESTATE,
BRIDLINGTON
EAST YORKSHIRE, YO16 4SJ

BS1180

Sht 4 of 6

INSTALLATION OF 9088 COMBINATION LAMP TO COMPLY WITH
LEGAL REQUIREMENTS FOR NUMBER PLATE ILLUMINATION.

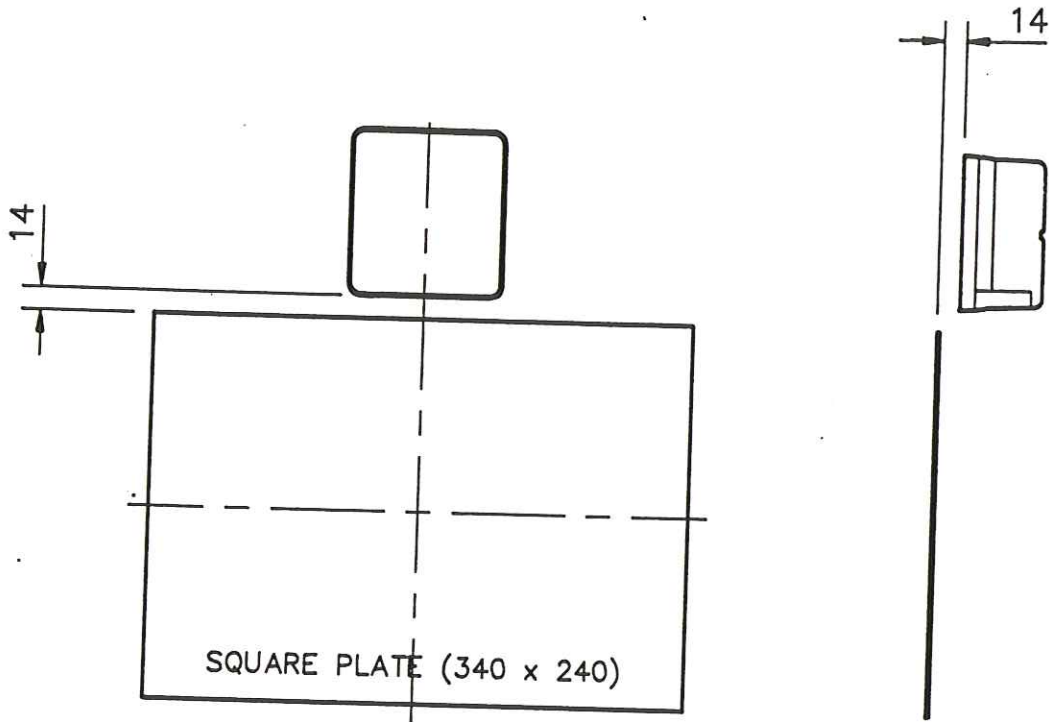

APPROVED MOUNTING POSITIONS



NOTE: MOUNTING SURFACE OF LAMP TO BE PARALLEL WITH
VERTICAL SURFACE OF THE REGISTRATION PLATE.
DIMENSIONS ARE MEASURED FORM THE BOTTOM EDGE OF
THE LAMP TO THE EDGE OF THE REGISTRATION PLATE.

R 0420	PRODUCTION REL	A	08/05/96	D.R.	BY
MOD No	REFERENCE	ISS	DATE		



BRITAX (P.M.G.) LTD.
BESSINGBY INDUSTRIAL ESTATE,
BRIDLINGTON
EAST YORKSHIRE, YO16 4SJ

BS 1180
Sht 5 of 6

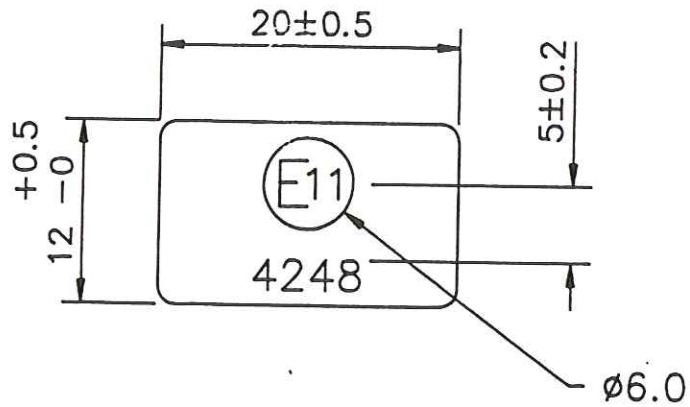

CHARACTER HEIGHTS

E	3.0	^{+0.2} -0
11	2.0	^{+0.2} -0
APPROVAL No. (4248)	2.0	^{+0.2} -0

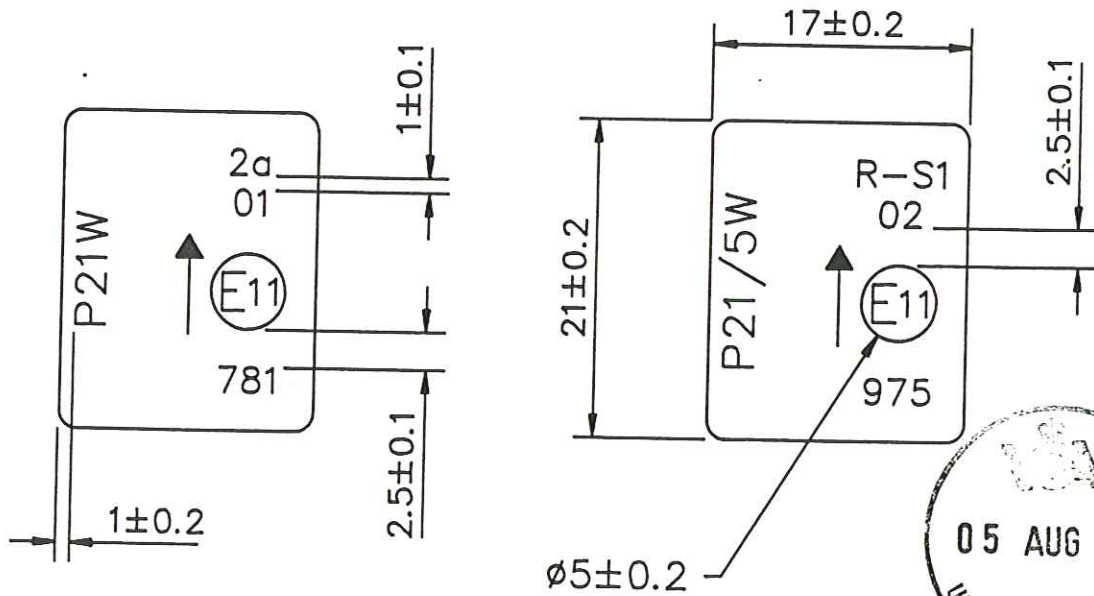

CHARACTER HEIGHTS

TOP CHARACTER (2a, R-S1)	1.7	^{+0.2} -0
E	2.5	^{+0.2} -0
11	1.7	^{+0.2} -0
AMENDMENT No. (01 & 02)	1.7	^{+0.2} -0
APPROVAL No. (781 & 975)	1.7	^{+0.2} -0
P21W, R5W	2.0	^{+0.2} -0



R 0420	PRODUCTION REL	A	08/05/96	D.R.	BY
MOD No	REFERENCE	ISS	DATE		



BRITAX (P.M.G.) LTD.
BESSINGBY INDUSTRIAL ESTATE,
BRIDLINGTON
EAST YORKSHIRE, YO16 4SJ

BS 1180
Sht 6 of 6

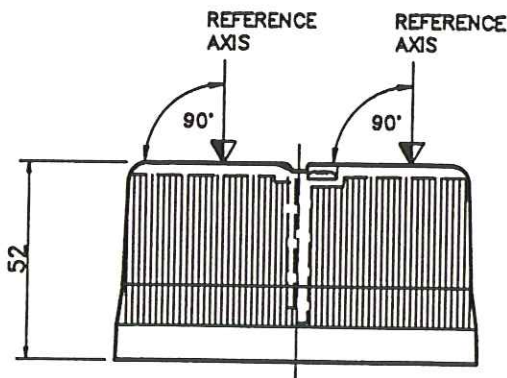
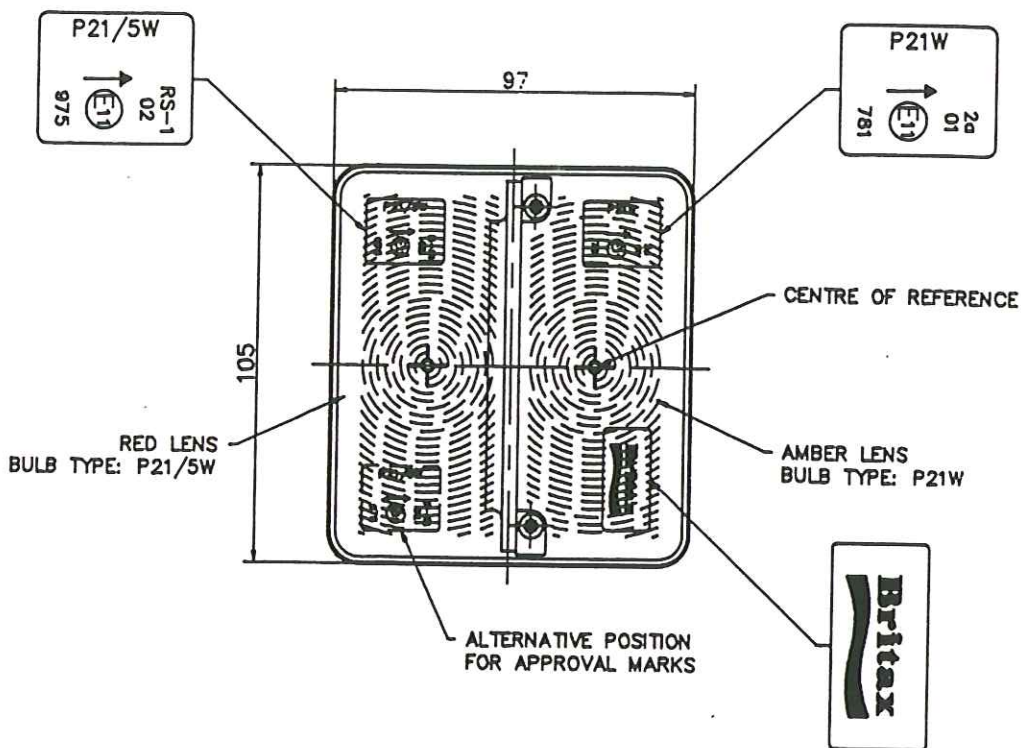

RIGHT HAND, AS DRAWN
LEFT HAND, SYMMETRICALLY OPPOSITE
REFERENCE AXIS, PARALLEL WITH ROAD SURFACE AND PARALLEL
WITH THE VEHICLE MEDIAN LONGTITUDINAL VERTICAL PLANE
THERMOPLASTIC BASE, BLACK
THERMOPLASTIC LENS, AMBER/ RED
LAMP MUST BE MOUNTED VERTICALLY WITH DIRECTION INDICATOR
OUTERMOST OR HORIZONTALLY WITH DIRECTION INDICATOR UPPERMOST.



BRITAX (P.M.G.) LTD.
BESSINGBY INDUSTRIAL ESTATE,
BRIDLINGTON
EAST YORKSHIRE, YO16 4SJ

BS 1181
Sht 1 of 4

R 0420	PRODUCTION REL.	A	08/05/96	D.R.	BY
MOD No	REFERENCE	ISS	DATE		

REAR POSITION (SIDE)/ INDICATOR

Report No PM000952/2-2

Page 16 of 18

9089
SERIES

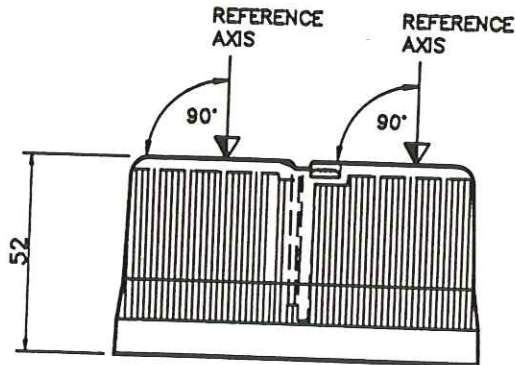
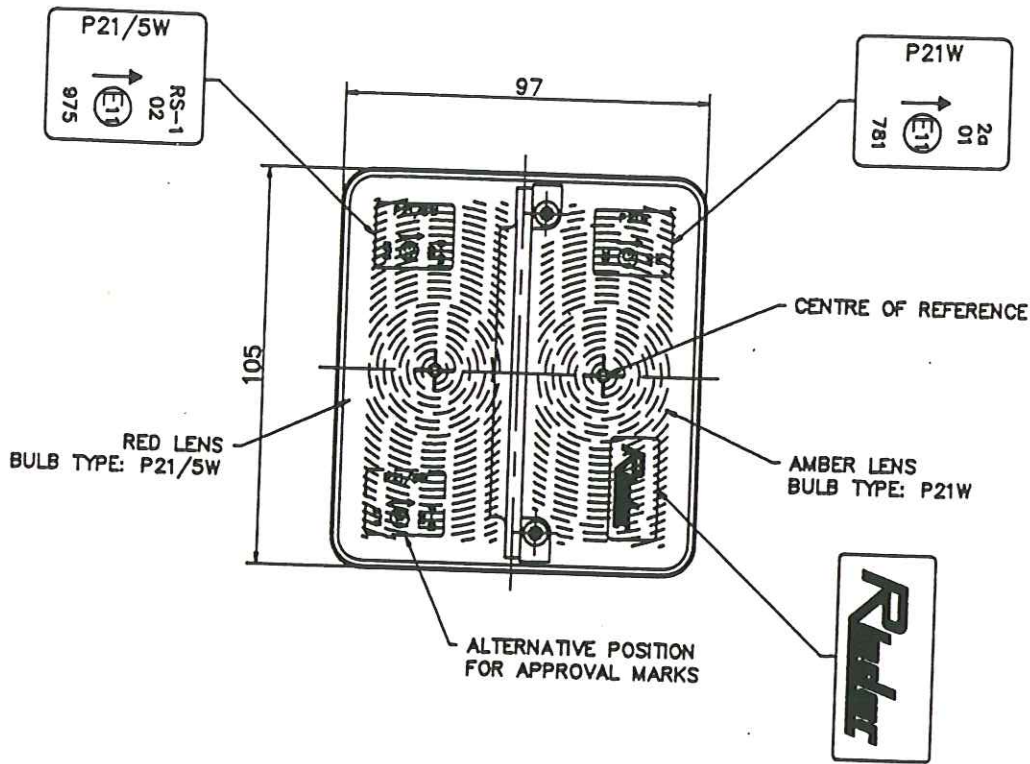

RIGHT HAND, AS DRAWN
LEFT HAND, SYMMETRICALLY OPPOSITE
REFERENCE AXIS, PARALLEL WITH ROAD SURFACE AND PARALLEL
WITH THE VEHICLE MEDIAN LONGTITUDINAL VERTICAL PLANE
THERMOPLASTIC BASE, BLACK
THERMOPLASTIC LENS, AMBER/ RED
LAMP MUST BE MOUNTED VERTICALLY WITH DIRECTION INDICATOR
OUTERMOST OR HORIZONTALLY WITH DIRECTION INDICATOR UPPERMOST.

R 0420	PRODUCTION REL.	A	08/05/96	D.R.	BY
MOD No	REFERENCE	ISS	DATE		



BRITAX (P.M.G.) LTD.
BESSINGBY INDUSTRIAL ESTATE,
BRIDLINGTON
EAST YORKSHIRE, YO16 4SJ

BS 1181
Sht 2 of 4

REAR POSITION (SIDE),
INDICATOR

Report No PM000952/2-2

Page 17 of 18

9089
SERIES

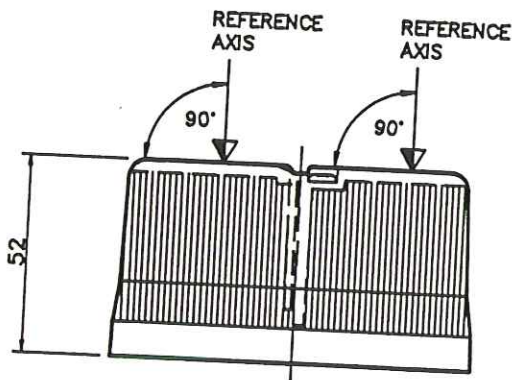
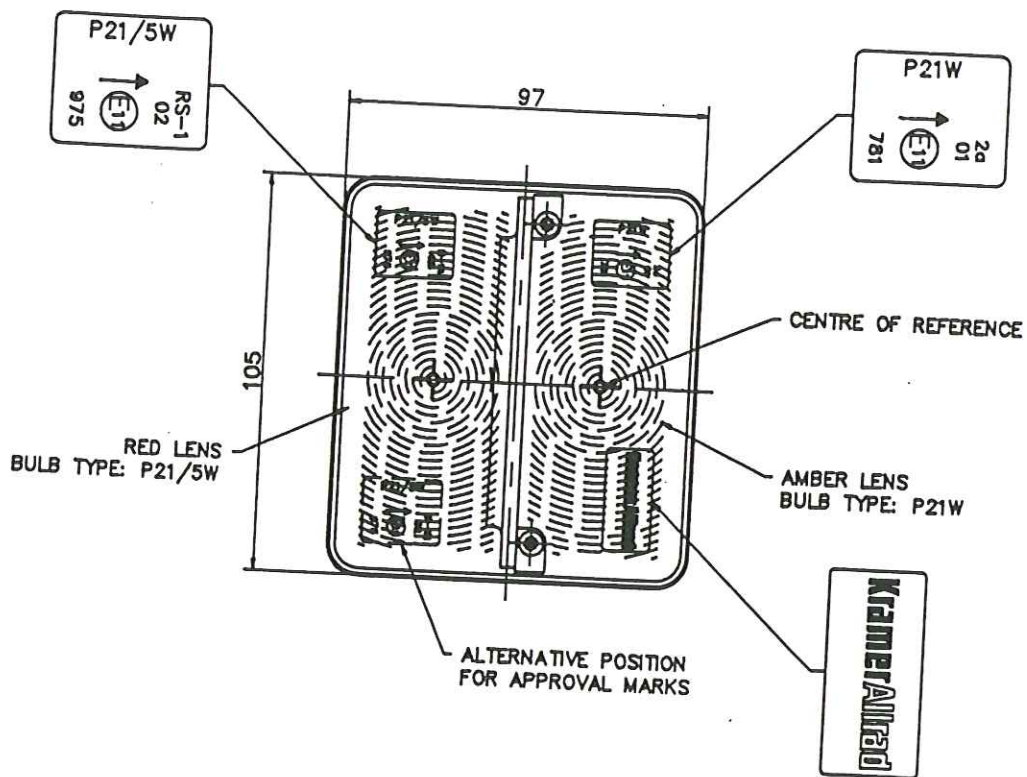

RIGHT HAND, AS DRAWN
LEFT HAND, SYMMETRICALLY OPPOSITE
REFERENCE AXIS, PARALLEL WITH ROAD SURFACE AND PARALLEL
WITH THE VEHICLE MEDIAN LONGITUDINAL VERTICAL PLANE
THERMOPLASTIC BASE, BLACK
THERMOPLASTIC LENS, AMBER/ RED
LAMP MUST BE MOUNTED VERTICALLY WITH DIRECTION INDICATOR
OUTERMOST OR HORIZONTALLY WITH DIRECTION INDICATOR UPPERMOST.

R 0420	PRODUCTION REL	A	08/05/96	D.R.	BY
MOD No	REFERENCE	ISS	DATE		



BRITAX (P.M.G.) LTD.
BESSINGBY INDUSTRIAL ESTATE,
BRIDLINGTON
EAST YORKSHIRE, YO16 4SJ

BS 1181

Sht 3 of 4

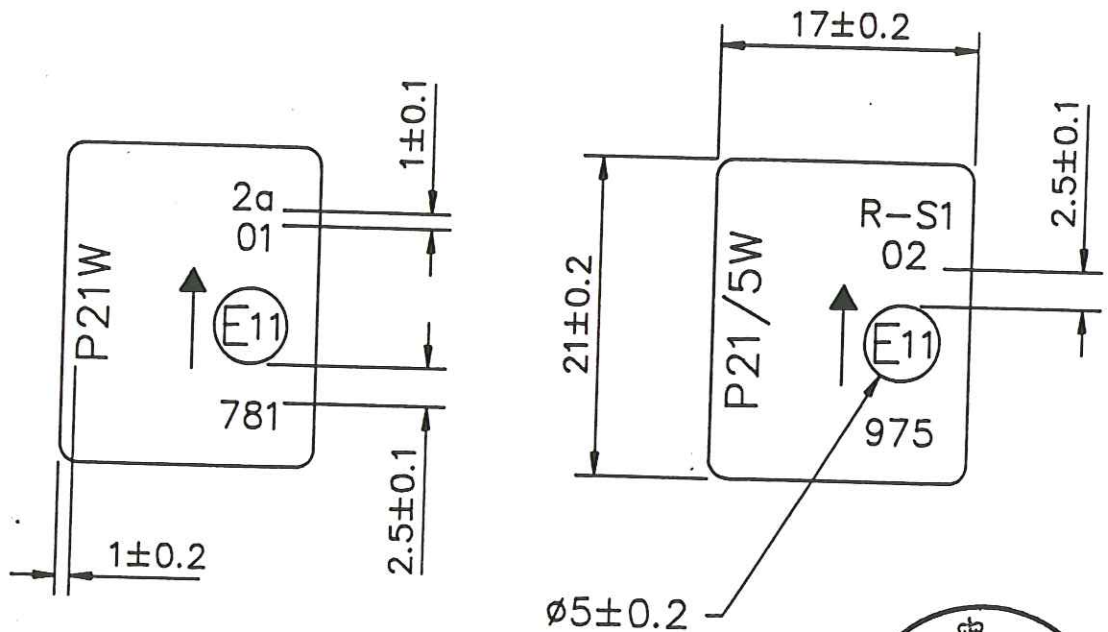

CHARACTER HEIGHTS

TOP CHARACTER (2a, R-S1)	1.7	+0.2	-0
E	2.5	+0.2	-0
11	1.7	+0.2	-0
AMENDMENT No. (01 & 02)	1.7	+0.2	-0
APPROVAL No. (781 & 975)	1.7	+0.2	-0
P21W, P21/5W	2.0	+0.2	-0

R 0420	PRODUCTION REL.	A	08/05/96	D.R.	
MOD No	REFERENCE	ISS	DATE	BY	



BRITAX (P.M.G.) LTD.
BESSINGBY INDUSTRIAL ESTATE,
BRIDLINGTON
EAST YORKSHIRE, YO16 4SJ

BS 1181
Sht 4 of 4